

FORM 8519
APRIL, 1922

LIST OF PARTS



MACHINE No. 112-1

THE SINGER MANUFACTURING COMPANY

From the library of: Diamond Needle Corp

COPYRIGHT, U. S. A., 1922, by THE SINGER MANUFACTURING CO.
ALL RIGHTS RESERVED FOR ALL COUNTRIES

INDEX

	PAGE
ACCESSORIES	13
FOOT LIFTER PARTS	13
IRON BASE	12
KNEE LIFTER PARTS	13
MACHINE NO. 112-1	7
NUMERICAL LIST OF PARTS	17
TABLE SUPPORT PARTS	14
THREAD UNWINDER	15

From the library of: Diamond Needle Corp.

NO.	PLATE	NAME
1012E	8501	Feed Connecting Rod Adjusting Screw ..
*12009	---	" " " Cap
1057E	8501	" " " " Screw
61813	8502	" Dog
190D	8507	" " Screw
32057	8501	" Eccentric with two 452c
452c	8507	" " Set Screw
64814	8501	" Lifting Eccentric with 452c and 462c
64815	8501	" " " Connection with 171E
		and 59019
171E	8501	Feed Lifting Eccentric Connection Adjust-
		ing Screw
59019	8501	Feed Lifting Eccentric Connection Gib...
50562c	8501	" " " " Hinge
		Screw
1520E	8501	Feed Lifting Eccentric Connection Hinge
		Screw Nut
452c	8507	Feed Lifting Eccentric Position Screw
462c	8501	" " " Set Screw
64816	8500	" " Rock Shaft
64817	8501	" " " " Bushing
1036c	8507	" " " " " Set Screw
64818	8503	" " " " Crank (back) with
		157E
157E	8503	Feed Lifting Rock Shaft Crank (back)
		Clamping Screw
64819	8503	Feed Lifting Rock Shaft Crank (front)
		with 157E and 428c
157E	8503	Feed Lifting Rock Shaft Crank (front)
		Clamping Screw
1027c	8503	Feed Regulating Screw Stud
1627c	8503	" " " " Nut
12290	8503	" " " " Washer
64820	8500	" Rocking Frame with four 452c
59211	8500	" " " Hinge Pin
64821	8503	" " " " " Bushing
1036c	8507	" " " " " " Set
		Screw
452c	8507	Feed Rocking Frame Hinge Pin Set Screw
36976	5698	Guide
120210	5698	" Lock Spring
201B	5698	" " " Screw
7071	8503	" " " " Washer
36977	5698	" Shank
907D	5698	" " Hinge Screw
38676	5698	" " " " Washer
1074B	8507	" Stud

NO.	PLATE	NAME
793B	8507	Guide Thumb Screw
7071	8503	" " " Washer
36978	5698	Guide complete, Nos. 201B, 793B, 1074B,
		36976, 36977, 120210 and two 7071
64822	8503	Looper with 34418
64823	8503	" Gate
1240c	8503	" " Hinge Screw
64824	8503	" " Spring
111D	8503	" " " Screw
64825	8503	" Shaft with 462c
64826	8503	" " Carrier
64827	8503	" " " Bushing
846c	8503	" " " " Set Screw ..
64828	8504	" " " Pitman
1132F	8507	" " " " Hinge Screw
		(left)
50562c	8501	Looper Shaft Carrier Pitman Hinge Screw
		(right)
1520E	8501	Looper Shaft Carrier Pitman Hinge Screw
		(right) Nut
64829	8503	Looper Shaft Coupling with two 462c
462c	8501	" " " Set Screw
462c	8501	" Set Screw
34418	8503	" Washer
64830	8505	Needle Bar (hollow) with 50165E and
		64850
64831	8505	Needle Bar Connecting Bracket with
		1056F and 50203E
50203E	8505	Needle Bar Connecting Bracket Clamping
		Screw
42055	8505	Needle Bar Connecting Link
40247	8505	" " " " Hinge Pin
1056F	8505	" " " " " " Set
		Screw
64832	8504	Needle Bar Frame
64833	8504	" " " Cam and Gear
64834	8504	" " " " " " Cover
176D	8507	" " " " " " "
		Screw
64835	8504	Needle Bar Frame Cam and Gear Stud
		(eccentric)
64836	8505	Needle Bar Frame Cam and Gear Stud
		Collar with two 1259c
1259c	8505	Needle Bar Frame Cam and Gear Stud
		Collar Set Screw
1036c	8507	Needle Bar Frame Cam and Gear Stud
		Set Screw

NO.	PLATE	NAME
64837	8504	Needle Bar Frame Driving Lever
64838	8505	" " " " " Connect- ing Link with 1012D and 59019
1012D	8501	Needle Bar Frame Driving Lever Connect- ing Link Adjusting Screw
59019	8501	Needle Bar Frame Driving Lever Connect- ing Link Gib
50562c	8501	Needle Bar Frame Driving Lever Connect- ing Link Hinge Screw
1520E	8501	Needle Bar Frame Driving Lever Connect- ing Link Hinge Screw Nut
64839	8505	Needle Bar Frame Driving Lever Hinge Stud
1036c	8507	Needle Bar Frame Driving Lever Hinge Stud Set Screw
64840	8505	Needle Bar Frame Guide
176F	8507	" " " " " Screw
37583	8505	" " " " " Hinge Stud
1036c	8507	" " " " " Set Screw
64841	8504	" " " " " Pitman
50562c	8501	" " " " " Hinge Screw
1520E	8501	" " " " " " "
		Nut
64842	8500	Needle Bar Frame Regulator with two 1120c
64839	8505	Needle Bar Frame Regulator Hinge Stud
64843	8505	" " " " " " "
		Bushing
1259c	8505	Needle Bar Frame Regulator Hinge Stud Bushing Set Screw
1984	8505	Needle Bar Frame Regulator Roller and Screw Stud
64844	8505	Needle Bar Frame Regulator Stop
220b	8505	" " " " " " " Screw
7806	8505	" " " " " " " "
		Washer
1120c	8507	Needle Bar Frame Regulator Set Screw
1374c	8505	" " " " " Regulating Screw Stud
1680c	8505	" " " " " " "
		Nut
42290	8503	Needle Bar Frame Regulating Screw Stud Washer
64845	8509	Needle Bar Lever with 1056F and two 1036c
42074	8505	Needle Bar Lever Ball Stud
1036c	8507	" " " " " Set Screw

NO.	PLATE	NAME
64846	8504	Needle Bar Lever Connecting Rod with 42059, 64847, 64848 and four 896E
*64847	—	Needle Bar Lever Connecting Rod Cap (lower)
896E	8507	Needle Bar Lever Connecting Rod Cap (lower) Screw
*42059	—	Needle Bar Lever Connecting Rod Cap (upper)
896E	8507	Needle Bar Lever Connecting Rod Cap (upper) Screw
42077	8506	Needle Bar Lever Connecting Rod Guide
171F	8501	" " " " " " "
		Screw
64848	8501	Needle Bar Lever Connecting Rod Oil Cup
64849	8504	Needle Bar Lever Hinge Stud
64836	8505	" " " " " Collar with two 1259c
1259c	8505	Needle Bar Lever Hinge Stud Collar Set Screw
1036c	8507	Needle Bar Lever Hinge Stud Set Screw
64850	8505	" " " Washer
50165F	8505	" " " " " Screw
1728c	8505	Needle Clamping Nut
64851	8506	Presser Bar
64852	8506	" " " Guide Bracket with 1454F and 50203F
50203F	8505	Presser Bar Guide Bracket Adjusting Screw
1454F	8506	Presser Bar Guide Bracket Clamping Screw
42007	8506	Presser Bar Guide Bracket Guide
452c	8507	" " " " " " " Set Screw
32123	8506	Presser Bar Lifter
32235	8506	" " " " " Hinge Stud
452c	8507	" " " " " " " Set Screw
51807	8506	" " " " " Roller and Screw Stud
64853	8504	" " " " " Spring (flat)
54722	8506	" " " " " Pin
32175	8506	" " " " " Stud
64854	8502	" " " " " Foot with 206F and 64855
64878	8502	" " " " " groove, for guiding a wire
64879	8502	Presser Foot for straight sewing and binding on wired hat frames
64880	8502	Presser Foot for overseaming chenille or other ornamental edging to straw braid

From the Library of Diamond Needle Corp.

NO.	PLATE	NAME
64855	8502	Presser Foot Extension
206F	8507	“ “ “ Screw
176D	8507	“ “ “ Screw
50132D	8507	Pressure Regulating Thumb Screw
1543D	8507	“ “ “ “ Lock Nut
2102	8506	Tension Disc
1560C	8506	“ Regulating Thumb Nut
50261C	8506	“ Screw Stud
54738	8506	“ Spring
64868	8506	“ Thread Guide
19068	8506	Thread Controller Bracket
330D	8507	“ “ “ Screw
32115	8506	“ “ Guide Plate with 19070
19070	8506	“ “ “ “ Stud
64856	8504	“ “ Releasing Rod
59042	8506	“ “ Spring
22430	8506	“ Eyelet (top of arm)
64857	8506	“ Guard
152E	8506	“ “ “ Screw
7071	8503	“ “ “ Washer
64858	8502	Throat Plate
64859	8502	“ “ Needle Hole Strip
64860	8502	“ “ “ “ “ Guide
1094F	8502	“ “ “ “ “ “ Screw
193F	8502	Throat Plate Needle Hole Strip Screw
1319F	8507	“ “ “ Screw (large)
207F	8507	“ “ “ “ (small)

IRON BASE

NO.	PLATE	NAME
64861	8509	Machine Base with three 356c
64862	8508	“ “ Bar
64863	8508	“ “ Foot with 356c
356C	8507	“ “ “ Set Screw
356C	8507	“ “ “ Set Screw
42088	8507	“ Cushion (felt)
935E	8507	“ “ “ Screw
64864	8509	Machine Base complete, Nos. 64861, three each 64862, 64863, wood screws 1½ in. No. 12 and four each 935E and 42088..

ACCESSORIES

NO.	PLATE	NAME
474E	8508	Machine Thumb Screw
14063	8508	“ “ “ Spring
9842	8507	“ “ “ Washer
36563	8508	Oiler (copper plated) with 36564
36564	8508	“ Spout, 5 in. long, with 120117
120117	8508	“ “ Washer (leather)
26151	8508	Screw Driver (large)
26485	8508	“ “ (small)
8908	8508	Wrench for 1520
19079	8508	“ “ 1728

FOOT LIFTER PARTS

NO.	PLATE	NAME
6439	—	Chain, 36 in. to 45 in., with 56864 and 56865
NOTE: When ordering No. 6439 give gauge required.		
4879	8508	Chain Connecting Link
56864	8508	“ Hook (large)
56865	8507	“ “ (small)
64865	8504	Lifting Lever
788D	8507	“ “ Hinge Screw
64866	8500	“ “ Link
1250C	8507	“ “ “ Guide Screw
1184D	8507	“ “ “ Hinge Screw
19081	8507	“ “ Spring
59051	8510	Treadle
7585	8508	“ Shaft
14210	8510	“ Stand
59052	8510	Treadle complete, Nos. 4879, 7585, 14210, 59051 and four wood screws 1¼ in. No. 12
64867	—	Foot Lifter complete, Nos. 788D, 1184D, 1250C, 6439, 19081, 59052, 64865 and 64866

KNEE LIFTER PARTS

NO.	PLATE	NAME
59055	—	Chain, length 18 in., with two 56865
56865	8507	“ Hook

NO.	PLATE	NAME
64865	8504	Lifting Lever.....
788d	8507	" " Hinge Screw.....
64866	8500	" " Link.....
1250c	8507	" " " Guide Screw.....
1184d	8507	" " " Hinge Screw.....
19081	8507	" " Spring.....
7124	8509	Rock Shaft.....
2764	8509	" " Hanger (back) with two wood screws 1 in. No. 10.....
16128	8509	Rock Shaft Hanger (front) with two wood screws 1 in. No. 10.....
16646	8509	Rock Shaft Knee Arm.....
16647	—	Rock Shaft Knee Arm complete, Nos. 2766, 2767 and 16646.....
2766	8509	Rock Shaft Knee Arm Hub with 356c.....
356c	8507	" " " " " Set Screw.....
2767	8509	" " " Plate with 356c.....
356c	8507	" " " " Set Screw.....
6337	8509	" " Lifting Bracket with two 356c.....
6338	8509	" " " " Hook.....
356c	8507	" " " " " Set Screw.....
356c	8507	" " " " " Set Screw.....
32134	8509	" " Spring.....
2770	8509	" " " Adjusting Dog with 356c.....
356c	8507	" " " " " Set Screw.....
2770	8509	" " Stop Dog with 356c.....
356c	8507	" " " " " Set Screw.....
32135	8509	Rock Shaft complete, Nos. 2764, 6337, 6338, 7124, 16128, 16647, 32134 and three 2770.....
64877	—	Knee Lifter complete, Nos. 788d, 1184d, 1250c, 19081, 32135, 59055, 64865 and 64866.....

TABLE SUPPORT PARTS

NO.	PLATE	NAME
41044	8510	Base with three wood screws 1¼ in. No. 14
41045	8510	Top with two wood screws 1¼ in. No. 14
41046	8510	Tube.....
1726p	8508	" Lock Nut.....
41047	—	Table Support Tube complete, Nos. 1726p and 41044 to 41046.....

THREAD UNWINDER

FOR ONE LARGE SPOOL OR ONE LARGE
CONE OF THREAD

NO.	PLATE	NAME
27623	2836	Spool Pin.....
155c	8507	" " Set Screw.....
41526	2836	" Rest.....
*60701	—	" " 41526 with 155c and 1149c....
41527	—	" " 60701 with 27623.....
1149c	8507	" " Set Screw.....
27940	2836	" Stand with 453c.....
41514	2836	" Weight, 4 in. diam., with 41515...
41515	8507	" " Centre Pin.....
27739	2836	Thread Cone (wood).....
41630	2836	" Guard with 208E and 41569.....
41569	8507	" " Eyelet.....
41637	2836	" " Rod (lower).....
41638	2836	" " " (upper).....
41639	2836	" " " Coupling with two 456c.....
456c	—	" " " Set Screw.....
41640	—	Thread Guard Rod complete, 30 in. long, Nos. 41637 to 41639.....
453c	8507	Thread Guard Rod Set Screw.....
208E	8507	" " Screw.....
41529	2836	Thread Unwinder complete, Nos. 27739, 27940, 41514, 41527, 41630, 41640 and three wood screws, 1 in. No. 12.....

From the library of: **Diamond Needle Corp.**

PLATE 2836—ONE-FOURTH SIZE

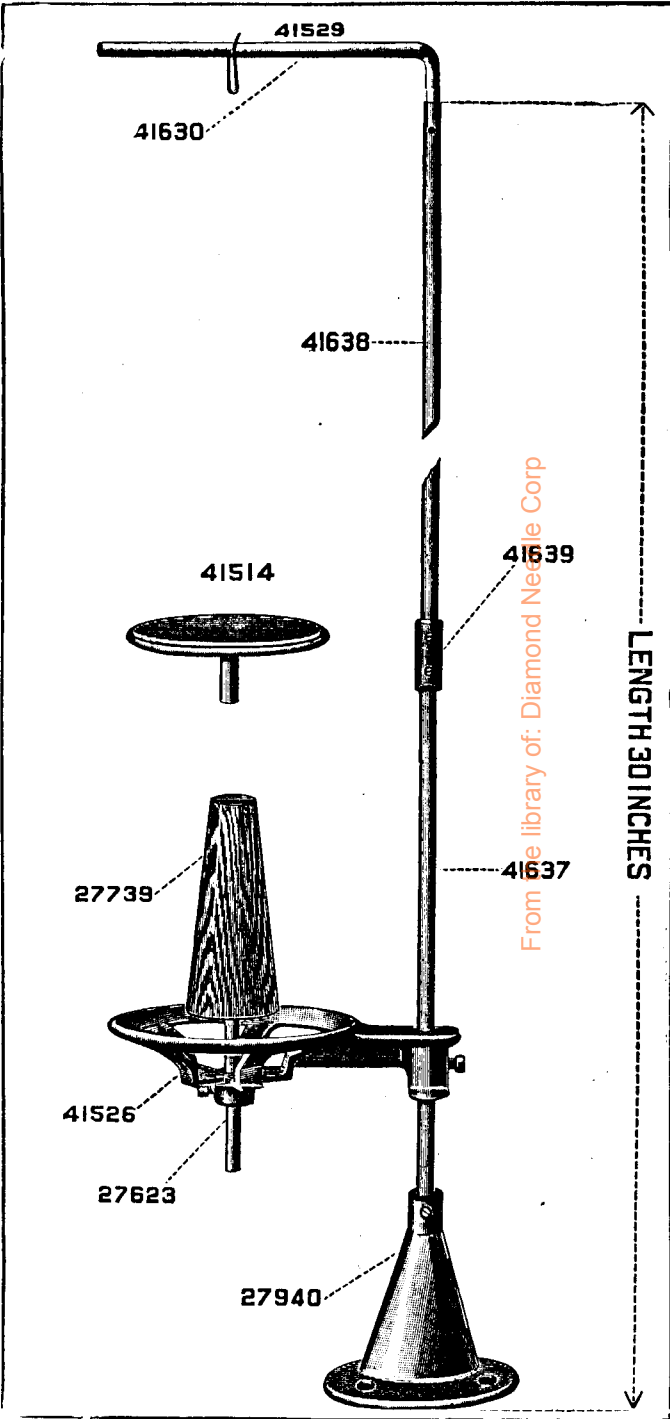

PLATE 5698—FULL SIZE

201

907

38676

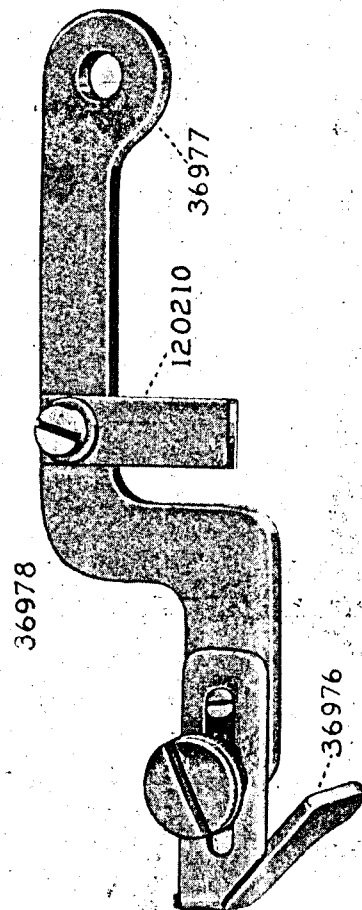

PLATE 8500—ONE-HALF SIZE

64802 64816 59211

34461

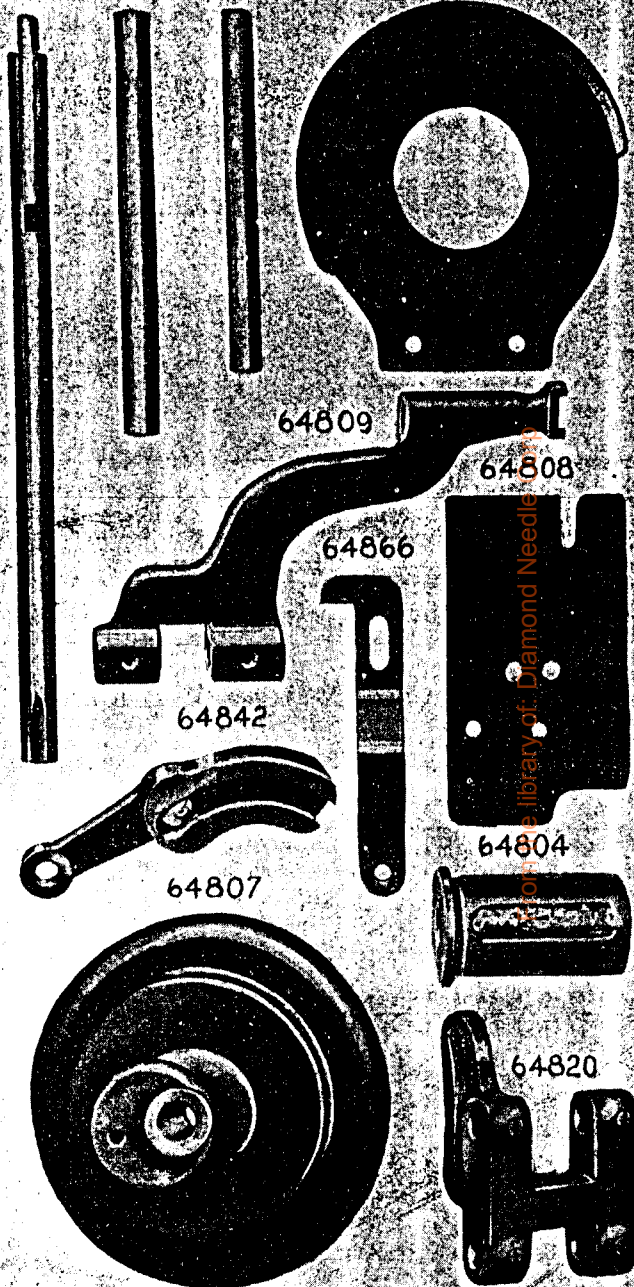

PLATE 8501—FULL SIZE

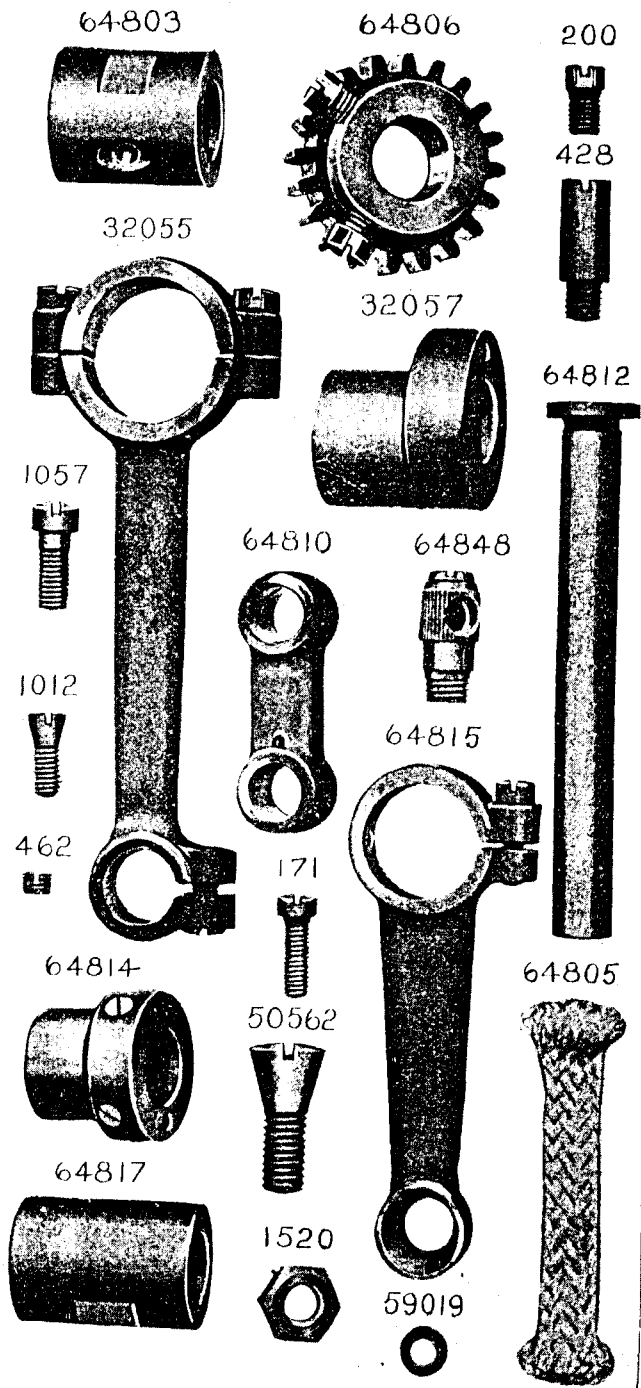
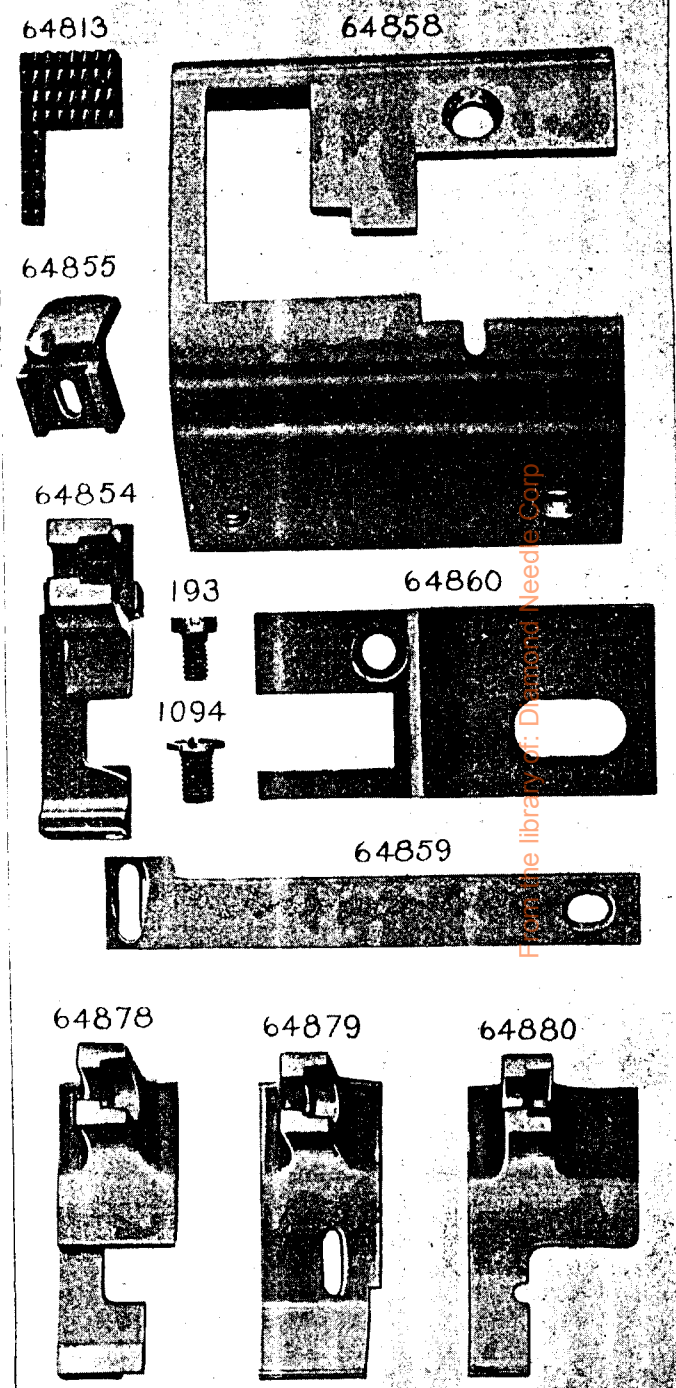

PLATE 8502—FULL SIZE



From the library of: Diamond Needle Corp

PLATE 8503—FULL SIZE

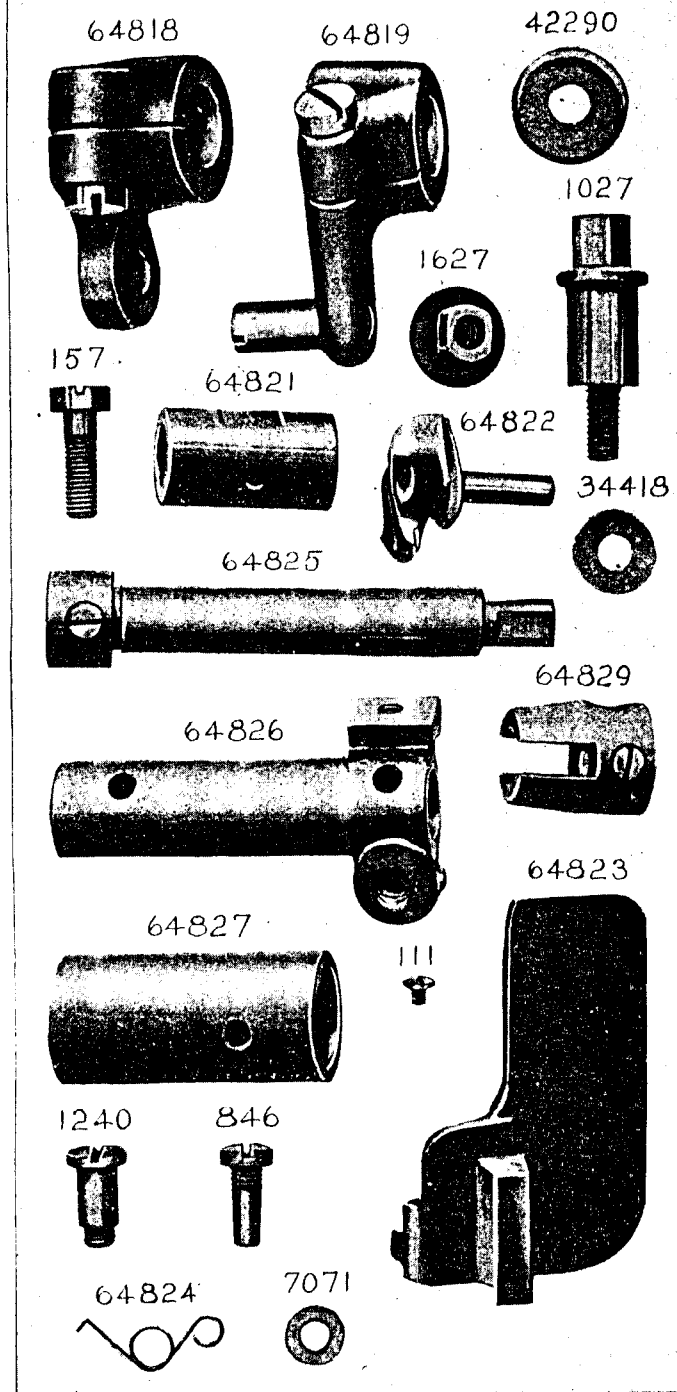
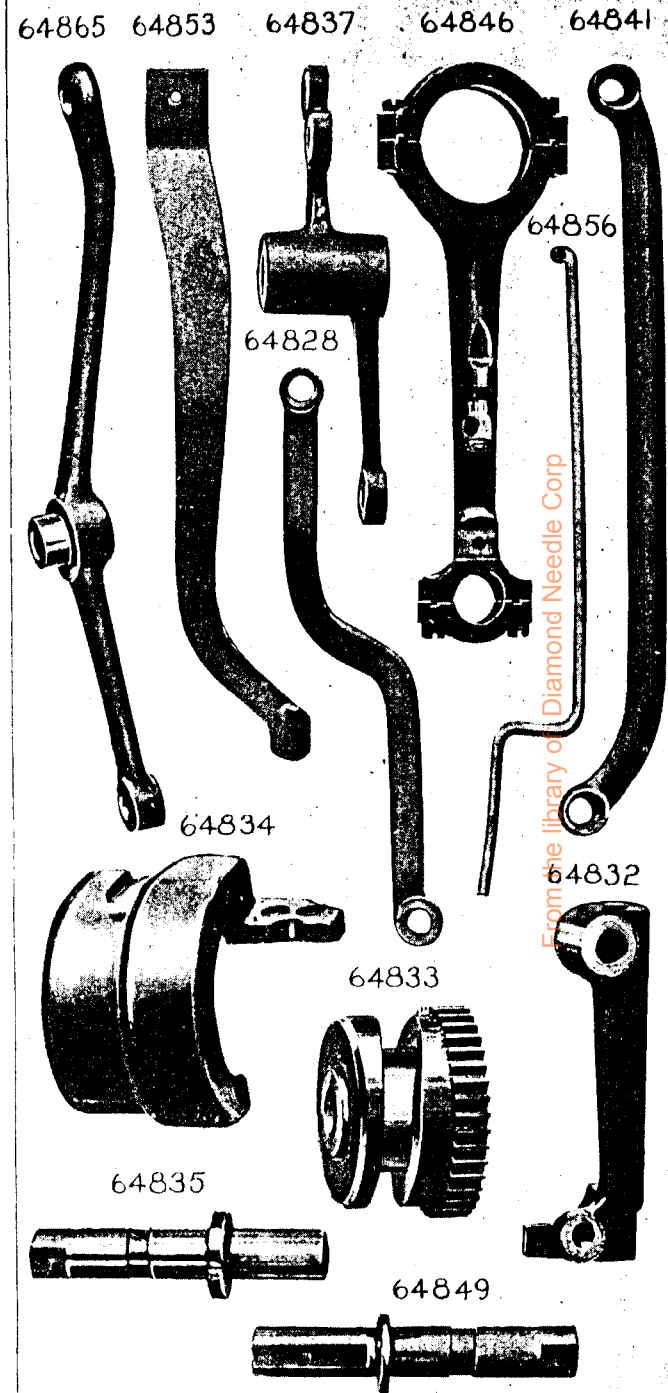

PLATE 8504—ONE-HALF SIZE



From the library of Diamond Needle Corp

PLATE 8507—FULL SIZE

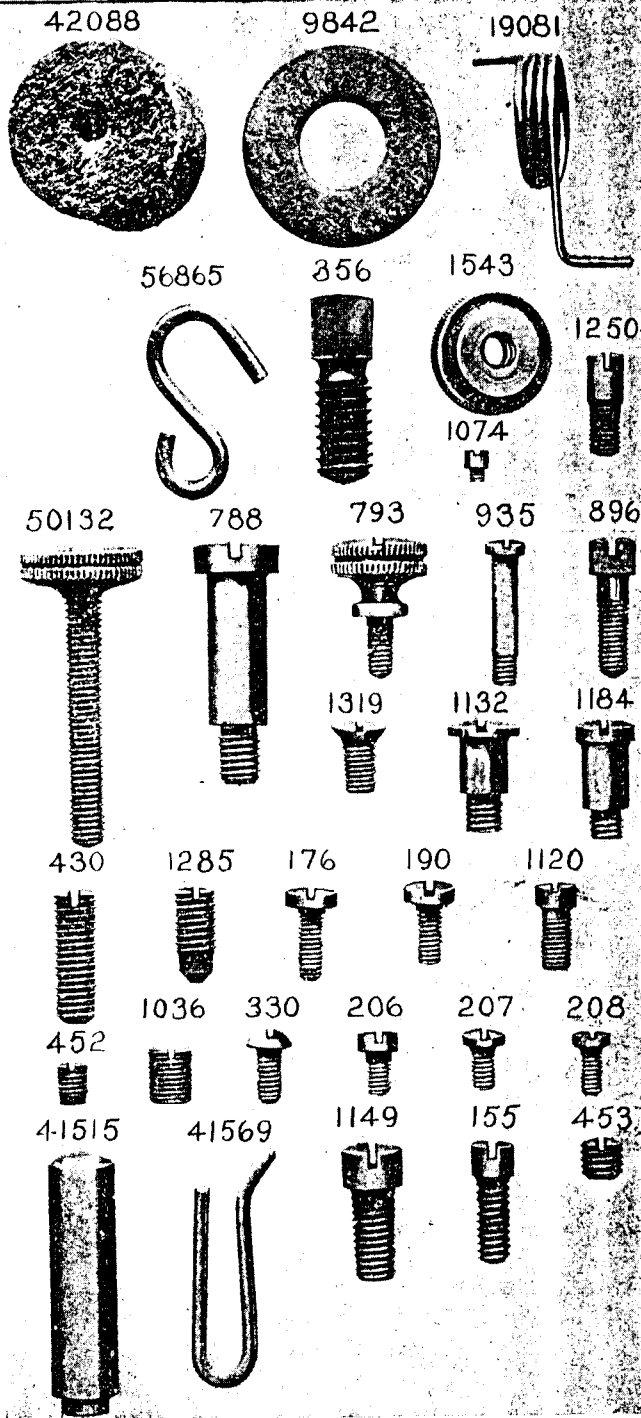
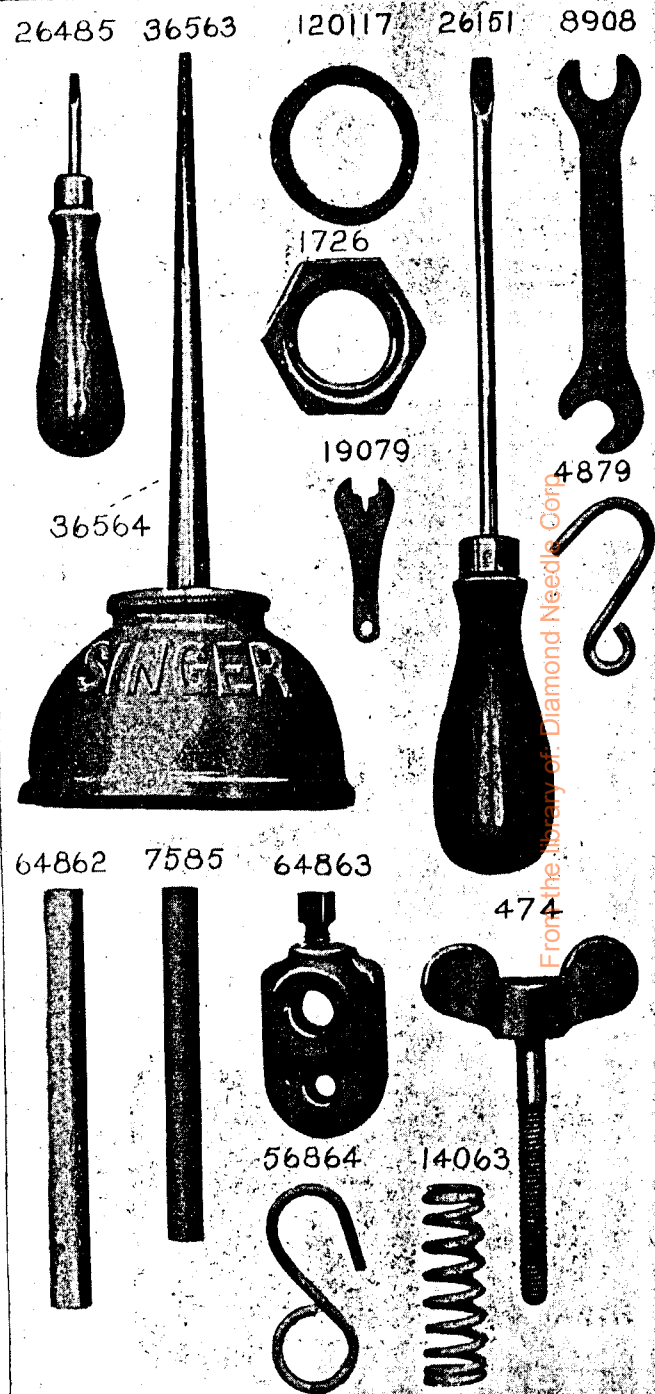

PLATE 8508—ONE-HALF SIZE



From the library of: Diamond Needle Corp.